

REINFORCEMENT LAYOUT FOR 6'-0" DIA MANHOLE FLAT TOP

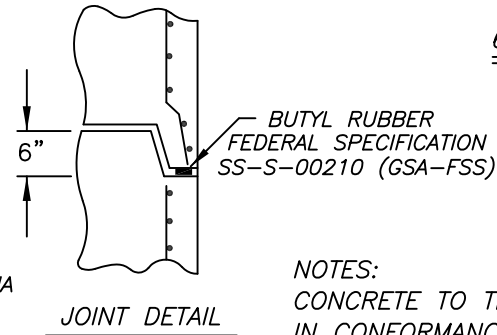

NOTES:  
 CONCRETE TO TEST 4000 PSI @ 28 DAYS IN CONFORMANCE WITH ASTM C-478  
 DESIGN FOR H2O LOADING

- APPROX. WEIGHTS:
- BASE = 4724 LBS
  - RISERS = 1800 LBS/FT
  - TOP SLAB = 4864 LBS
  - START RING = 4047 LBS

TYPICAL 6'-0" DIA MANHOLE WITH 4' DIA MANHOLE STACK

NOTE:

CONE DIMENSIONS	
DIA OPENING	HEIGHT
24"	36"
30"	36"

Precast Concrete Sales Co.  
 123 Route 303 Valley Cottage, N.Y. 10989  
 Tel. (845) 268-4949 - Fax (845) 268-4376

CONT.	
JOB	
6'-0" DIA CONCRETE MANHOLE WITH 48" MANHOLE STACK	
DATE	DRAWN BY
1/16	CLASSIC DESIGN
DRAWING NO.	
	3-6-S