

PLAN VIEW

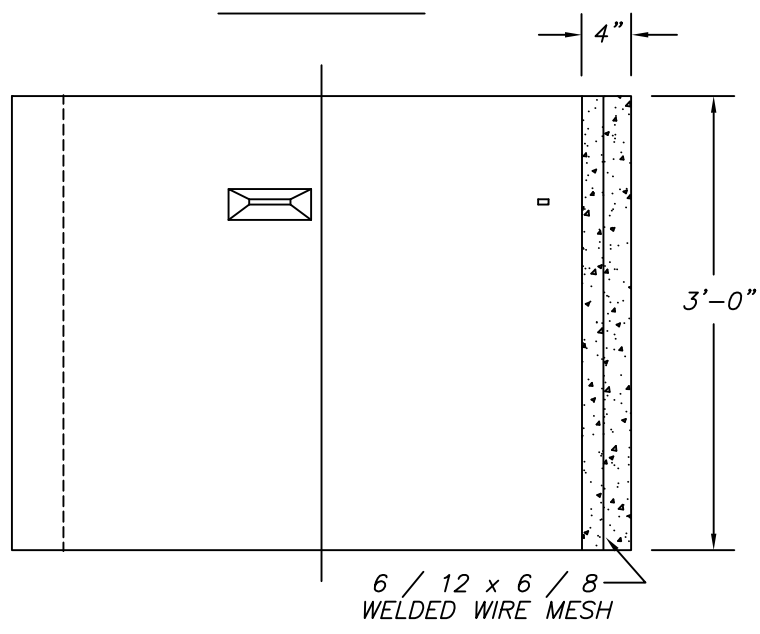

ELEVATION

SECTION

CONCRETE TO TEST 4000 PSI @ 28 DAYS  
 WELDED WIRE MESH ASTM A-185

SPECIFICATIONS			
RING HEIGHT	VOLUME C. F.	VOLUME GALLONS	APPROX. WEIGHT
3'-0"	126.7	948	3,675

Precast Concrete Sales Co. 123 Route 303 Valley Cottage, N.Y. 10989 Tel. (845) 268-4949 - Fax (845) 268-4376		
CONT.		
JOB		
8'-0" DIA. SOLID RING		
DATE	DRAWN BY	DRAWING NO.
1/16	CLASSIC DESIGN	708-S