

TOP VIEW

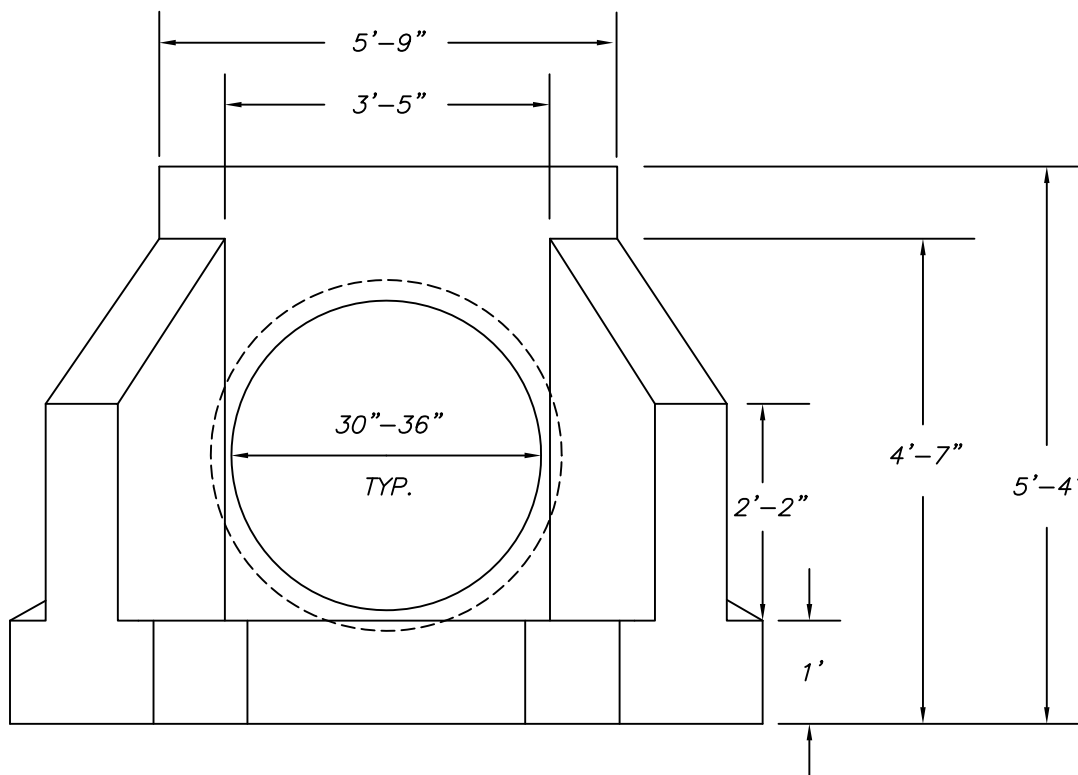

FRONT VIEW

NOTES :

1. MINIMUM 4,000 P.S.I. CONCRETE AT 28 DAYS WITH 5.5% A.E.
2. REINFORCEMENT—A.S.T.M. A615 GRADE 60, MINIMUM 1 1/2" COVER
3. ALL EXPOSED EDGES ARE CHAMFERED 1"
4. MATERIAL AND CONSTRUCTION SHALL COMPLY WITH PENN. D.O.T. PUB. 408
5. APPROX. WEIGHTS :
 30" = 8,500 LBS.
 33" = 8,325 LBS.
 36" = 8,150 LBS.

Precast Concrete Sales Co. 123 Route 303 Valley Cottage, N.Y. 10989 Tel. (845) 268-4949 - Fax (845) 268-4376		
CONT.		
JOB		
DW ENDWALL—30" TO 36" WITH FOOTER ONLY		
DATE	DRAWN BY	DRAWING NO.
1/16	CLASSIC DESIGN	9-DW 30-36